



PS10-2 with Nylon pressure connection shown

Tamper:

Cover incorporates tamper resistant fastener that requires a special key for removal. One key is supplied with each device. For optional cover tamper switch kit, order Stock No. 0090200. See bulletin #5401200 PSCTSK.

Models:

PS10-1 Canadian, PS10-1 Canadian and Brass Bushing
PS10-2 Canadian, PS10-2 Canadian and Brass Bushing

Service Use:

Automatic Sprinkler	NFPA-13
One or two family dwelling	NFPA-13D
Residential Occupancy up to four stories	NFPA-13R
National Fire Alarm Code	NFPA-72

Installation

The Potter PS10 Series Pressure Actuated Switches are designed for the detection of a waterflow condition in automatic fire sprinkler systems of particular designs such as wet pipe systems with alarm check valves, dry pipe, preaction, or deluge valves. The PS10 is also suitable to provide a low pressure supervisory signal; adjustable between 4 and 15 psi (0,27 and 1,03 BAR).

1. Apply Teflon tape to the threaded male connection on the device. (Do not use pipe dope)
2. Device should be mounted in the upright position (threaded connection down).
3. Tighten the device using a wrench on the flats on the device

Wiring Instructions

1. Remove the tamper resistant screw with the special key provided.
2. Carefully place a screwdriver on the edge of the knockout and sharply apply a force sufficient to dislodge the knockout plug. See Fig 9
3. Run wires through an approved conduit connector and affix the connector to the device.
4. Connect the wires to the appropriate terminal connections for the service intended. See Figures 2,4,5,6, and 8. See Fig 7 for two switch, one conduit wiring.

Testing

The operation of the pressure alarm switch should be tested upon completion of installation and periodically thereafter in accordance with the applicable NFPA codes and standards and/or the authority having jurisdiction (manufacturer recommends quarterly or more frequently).

Wet System

Method 1: When using PS10 and control unit with retard - connect PS10

UL, cUL, and CSFM Listed, FM and LPC Approved, NYMEA Accepted, CE Marked

Dimensions:

3.78" (9,6cm)W x 3.20" (8,1cm)D x 4.22" (10,7cm)H

Conduit Entrance:

Two knockouts provided for ½" conduit. Individual switch compartments and ground screws suitable for dissimilar voltages.

Enclosure:

Cover - Die-cast with textured red powdercoat finish, single cover screw and rain lip.
Base - Die-cast

Pressure Connection:

Nylon or Brass ½" NPT Male

Factory Adjustment:

4 - 8 PSI (0,27 - 0,55 BAR)

Pressure Range:

4-15 PSI (0,27-1,03 BAR)

Differential:

2 PSI (0,13 BAR)

Maximum System Pressure:

300 PSI (20,68 BAR)

Switch Contacts:

SPDT (Form C)
10.1 Amps at 125/250VAC, 2.0 Amps at 30VDC
One SPDT in PS10-1, Two SPDT in PS10-2

Environmental Specifications:

NEMA 4/IP66 Rated Enclosure - indoor or outdoor when used with NEMA 4 conduit fittings.
Temperature range: -40°F to 140°F (-40°C to 60°C)

into alarm port piping on the input side of retard chamber and electrically connect PS10 to control unit that provides a retard to compensate for surges. Insure that no unsupervised shut-off valves are present between the alarm check valve and PS10.

Method 2: When using the PS10 for local bell application or with a control that does not provide a retard feature - the PS10 must be installed on the alarm outlet side of the retard chamber of the sprinkler system.

Testing: Accomplished by opening the inspector's end-of-line test valve. Allow time to compensate for system or control retard.

Note: Method 2 is not applicable for remote station service use, if there is an unsupervised shut-off valve between the alarm check valve and the PS10.

Wet System With Excess Pressure

Connect PS10 into alarm port piping extending from alarm check valve. Retard provisions are not required. Insure that no unsupervised shut-off valves are present between the alarm check valve and the PS10.

Testing: Accomplished by opening the water by-pass test valve or the inspector's end-of-line test valve. When using end-of-line test, allow time for excess pressure to bleed off.

Dry System

Connect PS10 into alarm port piping that extends from the intermediate chamber of the alarm check valve. Install on the outlet side of the in-line check valve of the alarm port piping. Insure that no unsupervised shut-off valves are present between the alarm check valve and the PS10.

Testing: Accomplished by opening the water by-pass test valve.

Note: The above tests may also activate any other circuit closer or water motor gongs that are present on the system.

Fig. 1 Dimensions

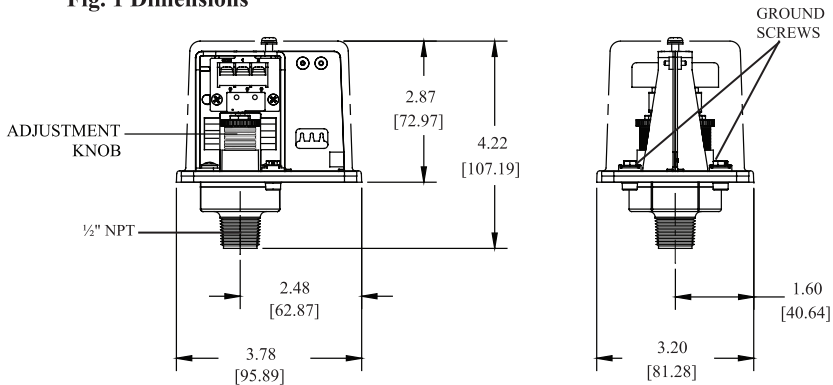

NOTE: To prevent leakage, apply teflon tape sealant to male threads only.

Fig. 2 Switch Clamping Plate Terminal

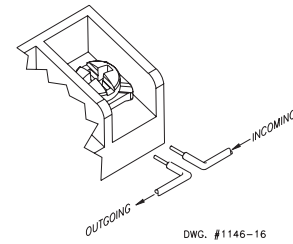

WARNING

An uninsulated section of a single conductor should not be looped around the terminal and serve as two separate connections. The wire must be severed, thereby providing supervision of the connection in the event that the wire become dislodged from under the terminal. Failure to sever the wire may render the device inoperable risking severe property damage and loss of life.

Do not strip wire beyond 3/8" of length or expose an uninsulated conductor beyond the edge of the terminal block. When using stranded wire, capture all strands under the clamping plate.

WARNING

Use of pipe joint cement may result in obstruction of the aperture and loss of signal.

Fig. 3 Typical Sprinkler Applications

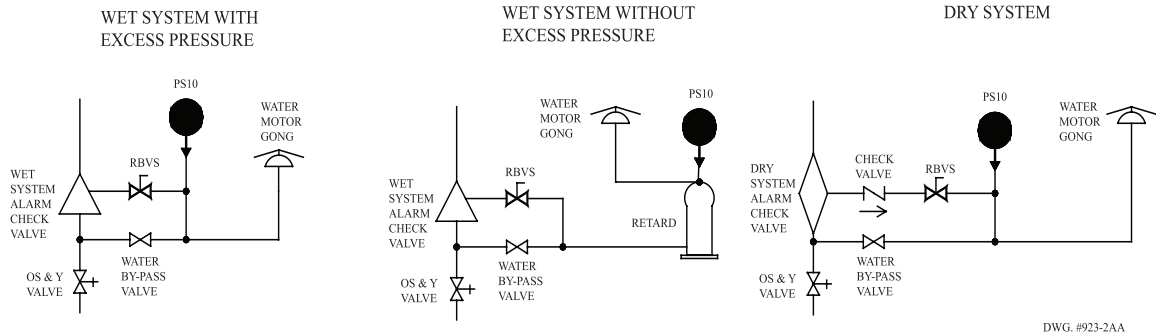

CAUTION

Closing of any shutoff valves between the alarm check valve and the PS10 will render the PS10 inoperative. To comply with NFPA-72 any such valve shall be electrically supervised with a supervisory switch such as Potter Model RBVS.

Fig. 4 Low Pressure Signal Connection

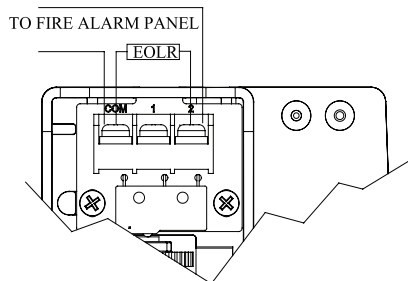

Fig. 5 Waterflow Signal Connection

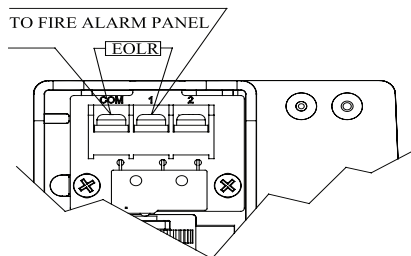

Fig. 6 Local Bell For Waterflow Connection

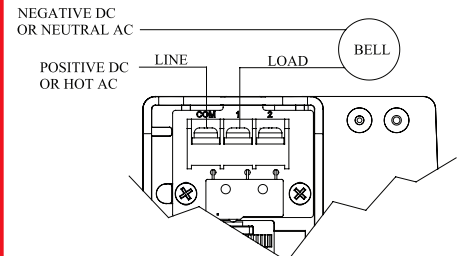

Fig. 7 One Conduit Wiring

Break out thin section of divider to provide path for wires when wiring both switches from one conduit entrance.

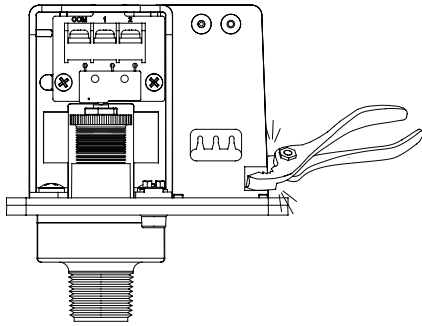

Fig. 8 Switch Operation

Terminal

C: Common

1: Closed when installed under normal system pressure.

2: Open when installed under normal system pressure. Closes on pressure drop. Use for low pressure supervision.

W/ PRESSURE APPLIED

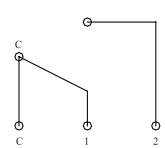

Terminal

1: Open with no pressure applied. Closes upon detection of pressure. Use for waterflow indication.

2: Closed with no pressure applied.

W/O PRESSURE APPLIED

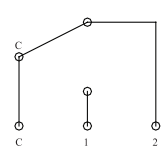
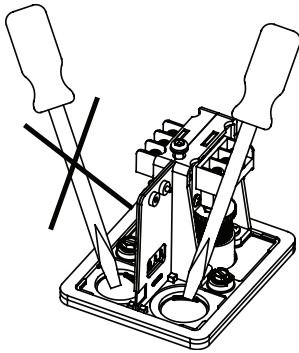

Fig. 9 Removing Knockouts



Ordering Information

Model	Description	Stock Number
PS10-1	Single Switch Canadian and Nylon Connection	1340105
PS10-1	Single Switch Canadian and Brass Connection	1340107
PS10-2	Double Switch Canadian and Nylon Connection	1340106
PS10-2	Double Switch Canadian and Brass Connection	1340108
	Hex Key	5250062
	Cover Tamper Switch Kit	0090200

WARNING

- Installation must be performed by qualified personnel and in accordance with all national and local codes and ordinances.
- Shock hazard. Disconnect power source before servicing. Serious injury or death could result.
- Read all instructions carefully and understand them before starting installation. Save instructions for future use. Failure to read and understand instructions could result in improper operation of device resulting in serious injury or death.
- Risk of explosion. Not for use in hazardous locations. Serious injury or death could result.

CAUTION

- Do not tighten by grasping the switch enclosure. Use wrenching flats on the bushing only. Failure to install properly could damage the switch and cause improper operation resulting in damage to equipment and property.
- To seal threads, apply Teflon tape to male threads only. Using joint compounds or cement can obstruct the pressure port inlet and result in improper device operation and damage to equipment.
- Do not over tighten the device, standard piping practices apply.
- Do not insert a foreign object between the microswitch and pressure adjustment knob to activate the switch.

Engineer/Architect Specifications Pressure Type Waterflow Switch

Pressure type waterflow switches; shall be a Model PS10 as manufactured by Potter Electric Signal Company, St Louis MO., and shall be installed on the fire sprinkler system as shown and or specified herein.

Switches shall be provided with a 1/2" NPT male pressure connection and shall be connected to the alarm port outlet of; Wet Pipe Alarm Valves, Dry Pipe Valves, Pre-Action Valves, or Deluge Valves. The pressure switch shall be actuated when the alarm line pressure reaches 4 - 8 PSI (0,27 - 0,55 BAR).

Pressure type waterflow switches shall have a maximum service pressure rating of 300 PSI (20,68 BAR) and shall be factory adjusted to operate on a pressure increase of 4 - 8 PSI (0,27 - 0,55 BAR).

Pressure switch shall have one or two form C contacts, switch contact rating 10.1 Amps at 125/250 VAC, 2.0 Amps at 30 VDC.

Pressure type waterflow switches shall have two conduit entrances one for each individual switch compartment to facilitate the use of dissimilar voltages for each individual switch.

The cover of the pressure type waterflow switch shall be Zinc die-cast with rain lip and shall attach with one tamper resistant screw. The Pressure type waterflow switch shall be suitable for indoor or outdoor service with a NEMA 4/IP66 rating.

The pressure type waterflow switch shall be UL Ulc and CSFM listed, FM and LPC approved and NYMEA accepted