

SPRINKLER SERIES GL-QR/INCH STANDARD COVERAGE, QUICK RESPONSE* THE INCH® FLAT PLATE CONCEALED PENDENT K-FACTOR 5.6

GENERAL DESCRIPTION

The Globe Series GL-QR/INCH sprinklers are Listed Quick Response concealed sprinklers which utilize a 3mm frangible glass bulb as the thermosensitive operating element. They are Listed and Approved as Standard Coverage sprinklers and are to be installed in accordance with the guidelines of the appropriate Installation Standard being mandated by the AHJ (i.e. NFPA 13). While providing the optimal aesthetic appeal with the low profile flat cover plate, the GL-QR/INCH additionally provides the largest vertical adjustment in the industry of a nominal 1". This nominal 1" adjustment allows for previously unrecognized installation flexibility resulting in a clean and tight final "fit" to the ceiling. The sprinkler is available in four temperatures and the cover plate is available in two temperatures. Additionally, the cover plate is available in three diameters. The GL-QR/INCH sprinklers are shipped with a protective cap which is temporarily removed during initial installation and replaced to protect against ceiling installation damage. The protective cap is removed and the flat cover plate is installed when the system is ready for service, See "Installation" steps within this document.

OPERATION

The soldered cover plate drops off the retainer assembly when exposed to heat, as from a fire, that has reached the plate's Listed temperature rating exposing the sprinkler above. Upon the releasing of the cover plate, the deflector, which is connected to two guide pins, drops down below the ceiling into its intended position. As heat encompasses the glass bulb operating element of the sprinkler, the fluid in the bulb expands, compressing the air bubble within the bulb. When the air bubble can no longer compress, the fluid expansion causes breakage of the glass bulb, resulting in release of the water seat assembly, and discharge of water from the sprinkler.

FINISHES AND ACCESSORIES

Flat Plate Finishes

- Chrome • White Painted • Black Painted
- Other finishes - *special order*

NOTE:

Factory painted cover plates must not be repainted. Non-factory applied paint may adversely delay or prevent sprinkler operation in the event of a fire.

Wrench

- P/N 332765

SEP 2019



3-5/16" DIAMETER
COVER PLATE



2-3/4" DIAMETER
COVER PLATE



4-1/2" DIAMETER COVER PLATE
SEISMIC IBC/ASCE/SEI CODES

TECHNICAL DATA

SIN

- GL5606

Approvals

- cULus Listed
- *FM approved for Standard Response only

Maximum Working Pressure

- 175 psi (12 bar)
- Factory tested to 500 psi (34 bar)

Minimum Operating Pressure

- 7 psi (48 kPa)

Temperature Ratings

- 135°F (57°C) Sprinkler, 135°F (57°C) Cover Plate
- 155°F (68°C) Sprinkler, 135°F (57°C) Cover Plate
- 155°F (68°C) Sprinkler, 155°F (68°C) Cover Plate
- 175°F (79°C) Sprinkler, 155°F (68°C) Cover Plate
- 200°F (93°C) Sprinkler, 155°F (68°C) Cover Plate

Materials of Construction

- Frame - bronze • Deflector - brass • Screw - brass
- Lodgement Wire - stainless steel • Bulb seat - copper
- Spring - nickel alloy • Seal - teflon
- Drop Pin -stainless steel
- Bulb - glass with alcohol based solution, 3mm
- Escutcheon Assembly - carbon steel

NOTE:

Users should refer to Globe's web site (www.globesprinkler.com) to ensure that the most recent technical literature is being utilized.

INSTALLATION

NOTICE

Do not install any bulb-type sprinkler if the bulb is cracked or there is loss of liquid from the bulb. Sprinklers should be tightened enough to obtain a leak-tight joint when water pressure is applied and/or hydrostatic test is performed. Sprinklers should not be overtightened as this can result in distortion and subsequent leakage. It is recommended not to exceed 14 ft.-lb. (19.0 Nm) torque for 1/2 inch NPT sprinkler threads.

- Step 1.** Sprinklers must be properly oriented.
- Step 2.** Remove the Protective Cap.
- Step 3.** With pipe-thread sealant applied to the pipe threads, hand tighten the sprinkler into the sprinkler fitting. *Note: Do not grasp the sprinkler by the deflector.*
- Step 4.** Wrench-tighten the sprinkler only using the concealed wrench P/N 332765. Wrenches are only to be applied to the sprinkler wrench flats or wrench hex. *Note: Do not apply wrench to frame arms.*
- Step 5.** Replace the Protective Cap by pushing it upwards until it bottoms out against the Support Cup. The Protective Cap helps prevent damage to the Deflector and Drop Pins during ceiling installation and/or during application of the finish coating of the ceiling.
NOTICE:
The system is considered Out of Service when the protective caps are in place.
- Step 6.** After the ceiling has been completed, remove and discard the Protective Cap. Verify that the Deflector moves up and down freely. If the Sprinkler is damaged or the Deflector does not move up and down freely, replace the entire Sprinkler. Do not attempt to modify or repair a damaged sprinkler.
- Step 7.** Thread on the Concealed Plate Assembly.

NOTE: As a convenience, either the Hand Held Installation Tool (P/N 332875) or the Extension Installation Tool (P/N 332876) may be used during the above installation procedure. Refer to GFS-860 for information on The INCH® installation tools.

CARE AND MAINTENANCE

Prior to installation, it is important to read and follow "The INCH® Sprinkler Caution" sheet (GFS-855) included within each box of sprinklers. This sheet is available on Globe's web site (www.globesprinkler.com).

Always obtain permission from the proper authorities to shut down the affected fire protection system and notify all personnel who may be affected by this action before closing a fire protection system main control valve for maintenance work on the system that it controls. Sprinklers should only be cleaned by means of gently dusting with a feather duster; otherwise, non-operation in the event of a fire or inadvertent operation may result.

When properly installed, there is a nominal 1/8" (3mm) air gap between the Cover Plate and the ceiling (FIGURE 1). This air gap is necessary for proper operation of the sprinkler by allowing heat flow from a fire to pass below and above the Cover Plate to help assure appropriate release of the Cover Plate in a fire situation. This annular "gap" must be maintained and should never be sealed or caulked.

Factory painted Cover Plates must not be repainted.

In accordance with NFPA 25, Sprinklers which are found to be leaking or exhibiting visible signs of corrosion must be replaced.

Automatic sprinklers must never be painted, plated, coated, or otherwise altered after leaving the factory.

Care must be exercised to avoid damage to the sprinklers—before, during, and after installation. Sprinklers damaged by dropping, striking, wrench slippage, or similar incidents, must be replaced.

The owner is responsible for the inspection, testing, and maintenance of their fire protection system and devices in compliance with this document, as well as with the applicable standards of the National Fire Protection Association (e.g. NFPA 25), in addition to the standards of any other authorities having jurisdiction.

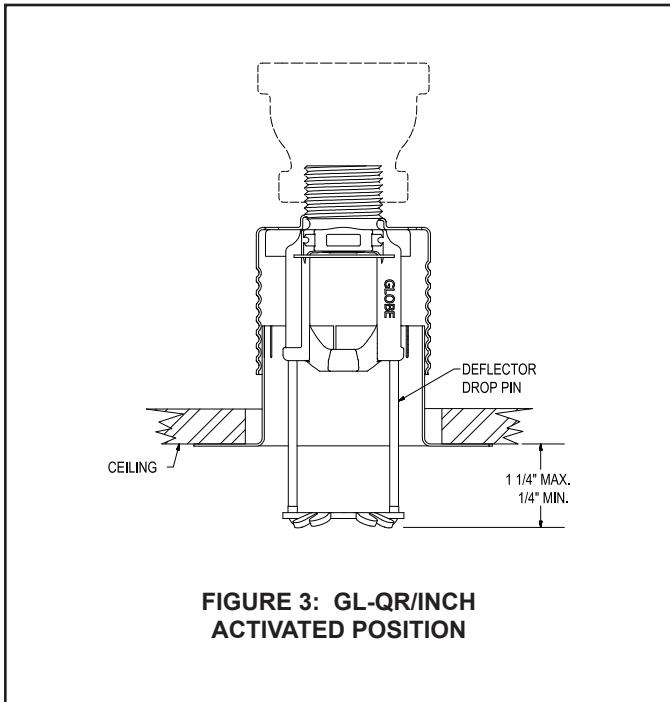
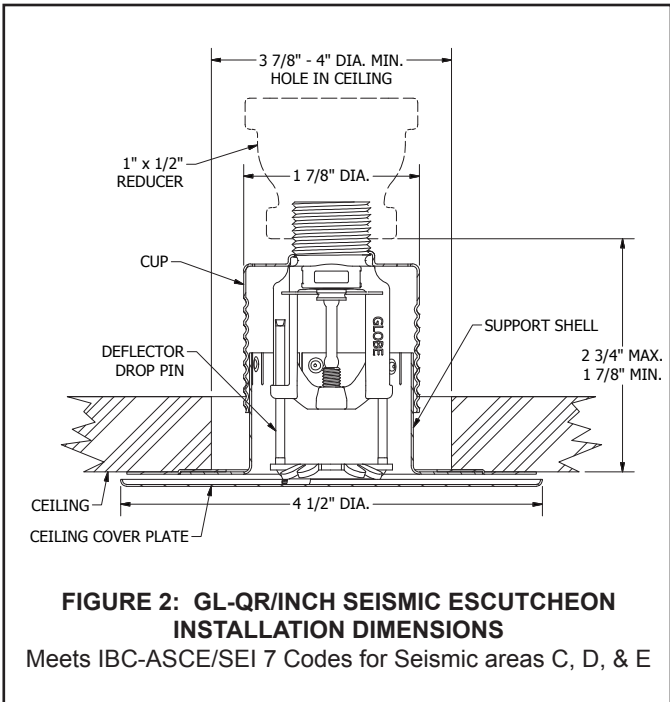
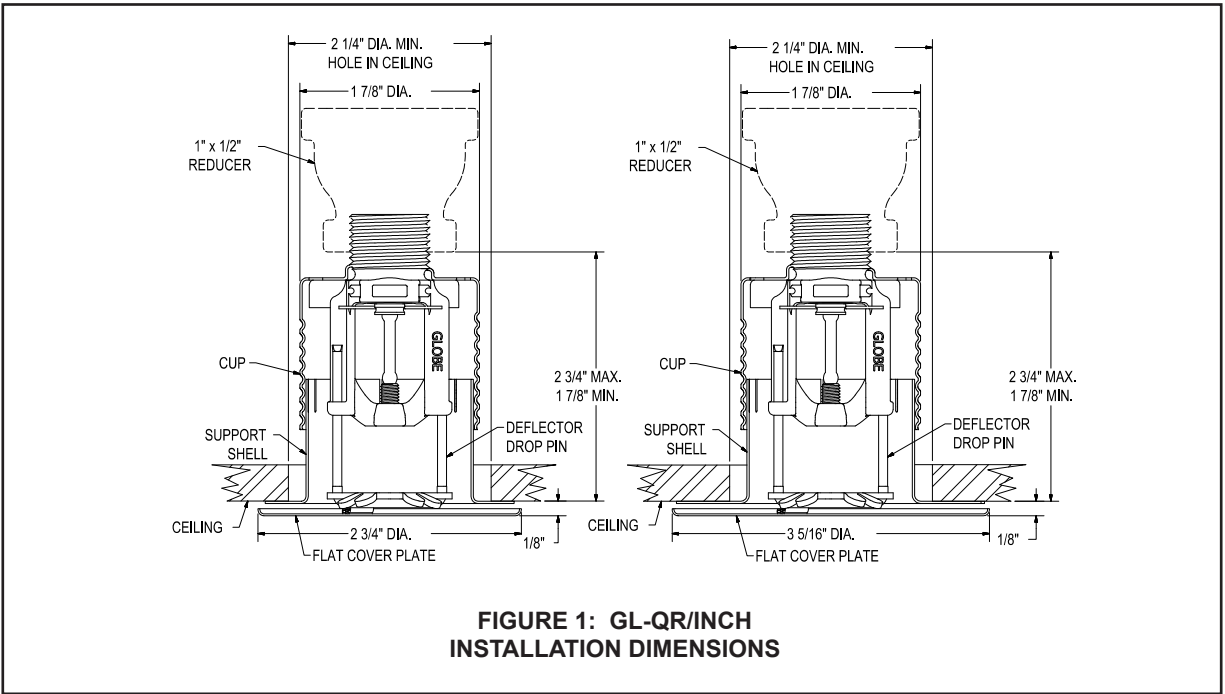

TABLE A: COVER PLATE PART NUMBERS

FLAT COVER PLATE SIZES	WHITE 135°F (57°C)	WHITE 155°F (68°C)	CHROME 135°F (57°C)	CHROME 155°F (68°C)	BLACK 135°F (57°C)	BLACK 155°F (68°C)	CUSTOM 135°F (57°C)	CUSTOM 155°F (68°C)
2 3/4" DIA.	332726	332731	332724	332729	332726-B	332731-B	332727	332732
3 5/16" DIA.	332706	332711	332704	332709	332706-B	332711-B	332707	332712
4 1/2" DIA (SEISMIC)	332822	332828	332821	332827	332822-B	332828-B	332823	332829

ORDERING INFORMATION

SPECIFY

- SPRINKLER
 - Quantity • SIN • Temperature Rating • Finish • Part Number

GL5606

SPRINKLERS

PART NUMBER

135°F (57°C)	560613501
155°F (68°C)	560615501
175°F (79°C)	560617501
200°F (93°C)	560620001

COVER PLATES

SEE TABLE A

- WRENCH
 - Quantity • Part Number 332765
- INSTALLATION TOOL
 - Quantity • Part Number

Handheld	332875
Used with Extension	332876
- PROTECTIVE CAP
 - Quantity • Part Number 332870

GLOBE® PRODUCT WARRANTY

Globe agrees to repair or replace any of its manufactured products found to be defective in material or workmanship for a period of one year from date of shipment.

For specific details of our warranty please refer to Price List Terms and Conditions of Sale (Our Price List).

