



**THE INCH<sup>®</sup>**  
**QUICK RESPONSE**  
**AUTOMATIC SPRINKLERS**  
**GL SERIES DRY TYPE**  
**ONE INCH ADJUSTABLE**  
**FLAT PLATE CONCEALED PENDENT**

**DESCRIPTION AND OPERATION**

The Globe Quick Response Series GL-QR/DRY/INCH Dry Type Adjustable Concealed Pendent Sprinkler is designed for use in special applications such as freezing environments and conditions where sediment or foreign materials might accumulate in ordinary drop nipples. All that is seen at the ceiling is a 3 5/16" diameter ceiling plate color finished to match the specifier's exact requirements. The Quick Response Series GL-QR/DRY/INCH Dry Adjustable Concealed Sprinkler may be virtually invisible as it does not interrupt the "smooth flow" of the ceiling. The quick response sprinkler with operation approximately six times faster than ordinary sprinklers, should be used advisedly and under the direction of approving authorities having jurisdiction. Globe's Dry Adjustable Concealed Sprinkler utilizes its frangible 3mm glass bulb type sprinkler which is located above the ceiling and concealed from view by the ceiling plate. The plate is soldered to the sprinkler special upper support assembly in three places. Upon the application of sufficient heat, the plate falls to the floor exposing the pendent spray sprinkler. At the ampule's rated temperature, the sprinkler opens releasing the bulb seat, causing the inner tube assembly to move allowing the spring assembly to pivot alongside the inner tube. At this time, water flows through the sprinkler and is distributed by the deflector in an approved discharge pattern.

The provided protective cap needs to be removed in order to install the sprinkler with the proper wrench. The protective cap must be replaced on the sprinkler until the time the cover plate is to be installed. The "push on - screw off" designed cover plate is easily installed and with a nominal 1" inch of adjustment makes it easier to get a proper fit at the ceiling.

**TECHNICAL DATA**

- See reverse side for Approvals and Specifications.
- Temperature Ratings -
  - 135°F (57°C) Sprinkler, 135°F (57°C) Cover Plate
  - 155°F (68°C) Sprinkler; 135°F (57°C) Cover Plate
  - 175°F (79°C) Sprinkler; 155°F (68°C) Cover Plate
  - 200°F (93°C) Sprinkler; 155°F (68°C) Cover Plate
- Water Working Pressure Rating - 175 psi (12 Bars)
- Factory tested hydrostatically to 500 psi (34 Bars)
- Maximum low temperature glass bulb rating is -67°F (-55°C)
- Frame - bronze • Deflector - brass • Screw brass • Bulb Seat - brass
- Spring - nickel alloy • Seal - teflon • Retainer - brass • Pin - stainless steel
- Torsion Spring - stainless steel • Lodgement Wire - stainless steel
- Bulb - glass with alcohol based solution, 3mm size • Orifice Insert - brass
- 1"NPT • Outer Tube - galvanized steel pipe • Inner Tube - stainless steel
- Cover Plate - brass • Upper Escutcheon Assembly - plated steel



**SERIES GL-QR/DRY/INCH**  
**FLAT PLATE DRY**  
**CONCEALED PENDENT**

**NOTE: Globe's wrench P/N 337014 must be used to install this sprinkler.**

**•SPRINKLER TEMPERATURE RATING/CLASSIFICATION and COLOR CODING**

CLASSIFICATION	AVAILABLE SPRINKLER TEMPERATURES		BULB COLOR	N.F.P.A. MAXIMUM CEILING TEMPERATURE	
	135°F/155°F	57°C/68°C		100°F	38°C
ORDINARY	175°F/200°F	79°C/93°C	ORANGE/RED	150°F	66°C
INTERMEDIATE			YELLOW/GREEN		

# THE INCH® QUICK RESPONSE AUTOMATIC SPRINKLERS GL SERIES DRY TYPE ONE INCH ADJUSTABLE FLAT PLATE CONCEALED PENDENT

## SPECIFICATIONS

SIN	NOMINAL "K" FACTOR	THREAD SIZE	LENGTH	FLAT COVER PLATE FINISHES***
GL5634	5.6 (80 metric)	1"NPT	cULus Variable to 48" FM Variable to 36"	Chrome White Painted Other Painted Finishes <sup>1,2</sup>
GL8134	8.0 (115 metric)			

NOTE: METRIC CONVERSIONS ARE APPROXIMATE.

<sup>1</sup>FINISHES AVAILABLE ON SPECIAL ORDER.

<sup>2</sup>FOR PAINTED PLATES OTHER THAN WHITE, CONTACT GLOBE FOR ORDERING SPECIFICATIONS.

\*\*\*FACTORY PAINTED COVER PLATES MUST NOT BE REPAINTED. NON-FACTORY APPLIED PAINT MAY ADVERSELY DELAY OR PREVENT SPRINKLER OPERATION IN THE EVENT OF A FIRE.

## APPROVALS

STYLE	SIN	HAZARD <sup>1</sup>	TEMPERATURE				cULus	*FM	MIN. DISTANCE BETWEEN SPRINKLERS Feet (Meters)
			**135°F (57°C) Sprinkler with 135°F (57°C) Flat Cover Plate	155°F (68°C) Sprinkler with 135°F (57°C) Flat Cover Plate	**175°F (79°C) Sprinkler with 155°F (68°C) Flat Cover Plate	200°F (93°C) Sprinkler with 155°F (68°C) Flat Cover Plate			
Adjustable Concealed Pendent	GL5634	LH/OH	X	X	X	X	X	X	6 (1.8)
	GL8134	LH/OH	X	X	X	X	X	---	

<sup>1</sup>SPRINKLERS SHALL BE LIMITED AS PER THE REQUIREMENTS OF NFPA13 AND ANY OTHER RELATED DOCUMENTS.

\*FM APPROVED AS STANDARD RESPONSE

\*\*NO FM APPROVALS

OH: ORDINARY HAZARD

LH: LIGHT HAZARD

## CROSS SECTION

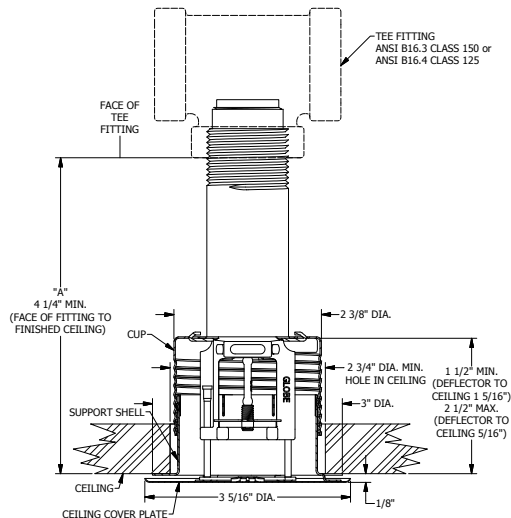

## 1" ADJUSTMENT FLAT PLATE CONCEALED PENDENT

FLAT COVER PLATE SIZE	135°F (57°C) PART #	155°F (68°C) PART #
3 5/16" DIA.		
WHITE	332892	332898
CHROME	332891	332897

## IMPORTANT INSTALLATION DATA

Globe GL Series Dry Concealed sprinklers should be installed in accordance with the requirements set forth in NFPA 13. These sprinklers are to be installed using a pipe wrench applied to the outer tube. When this is not possible, the proper sprinkler head wrench may be used with extreme care for lengths up to approximately 18". Excessive force may distort the frame thus destroying the unit.

When installed in a wet system extending into a freezing area see chart on Dry Caution sheet for minimum exposed barrel length to prevent ice plugs. Please refer to our Dry Caution Sheet for further important installation data.

## ORDERING INFORMATION SPECIFY

- Quantity • SIN • Style • Orifice • Temperature
- Finishes desired • Quantity - Wrenches - P/N 337014
- Quantity - Protective Caps - P/N 332868
- "A" Dimension - Distance from face of fitting to finished ceiling.

## GLOBE® PRODUCT WARRANTY

Globe agrees to repair or replace any of its own manufactured products found to be defective in material or workmanship for a period of one year from date of shipment.

For specific details of our warranty please refer to Price List Terms and Conditions of Sale (Our Price List).